

SCENEMASTER

HO SCALE TRACKED EXCAVATOR 949-11005

Thanks for purchasing this Walthers SceneMaster kit. All parts are styrene, so use compatible glue and paint to assemble and finish your model. PLEASE NOTE: Parts are assembled in numerical sequence: #1 to #2, #1& 2 to #3 etc. With careful assembly, several parts are positionable; parts marked * snap in place, but may be glued if desired.

One of the most widely used of all modern construction machines, hydraulic excavators are the first choice for digging in rock or soil and are also used to move a variety of materials. Most American contractors prefer units with steel tracks for off-road work. Although they need to be delivered to the job by truck or train, steel tracks spread the weight over a wider area, a big plus during wet weather or when working on soft or muddy terrain, have a relatively small turning radius, and aren't affected by debris. The machines consist of two major parts, the undercarriage, which includes the tracks and hydraulic drive mechanism, and a superstructure known as the "house." This is fitted with the control cab, engine, hydraulic pumps, counterweights, and the "arm," so called as it bends in two places like a human wrist and elbow, with an upper boom and lower bucket for digging. The arm does the actual work, with control of its four functions split between a pair of joysticks. On most units it only moves up and down, and the entire house is rotated to deliver each load exactly where it's needed. Today, hydraulic excavators come in a full range of sizes and capacities, often equipped with a variety of attachments to take on demolition, drilling, heavy lifting and other work. For additional products to complete your model, see your participating hobby dealer, check out the latest Walthers Model Railroad Reference Book or visit us online at walthers.com.

1) Track Frames - make 2 as follows: Insert - do not glue - Front Idlers* (2x 3; one each side) into openings on front of Right (1) and Left (2) Track Frames; secure in place by inserting - do not glue - Idler Axles* (2x 4 one each side) as shown.

2) Push - do not glue - Drive Wheels* (2x 5) over ends of Final Drives* (2x 6) and insert - do not glue - completed assembly into opening at rear of Track Frames as shown.

3) Carefully thread center guides on inside of Tracks (2x 7) over Sprocket and Idler, and along bottom rollers molded on Frames. Clip the ends of the Tracks together, and secure with a bit of glue.

4) Glue Underframe Lower (8) and Upper (9) halves together. Glue Guard (10) to slot on top half as shown.

5) Insert - do not glue - Swing Drive* (11) over center pin on Upper Underframe. Carefully glue Cap (12) to top of pin; make sure the drive turns freely. Glue pins on top of Drive to openings at front of Cab Base (13) as shown. Glue Boom Support (14) to insert area on front of base.

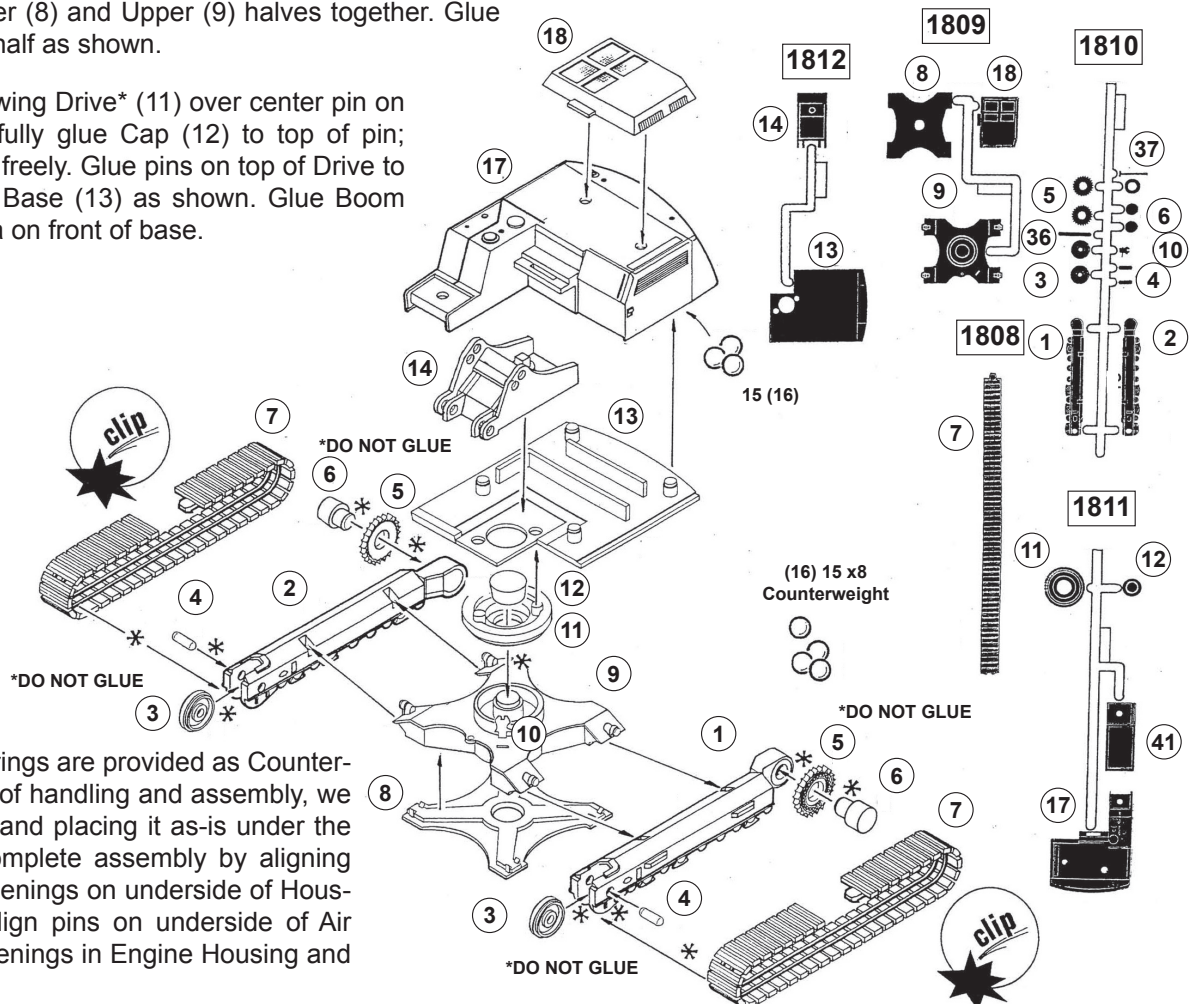

6) A bag of small ball bearings are provided as Counterweights (15/16); for ease of handling and assembly, we suggest folding this to fit and placing it as-is under the Engine Housing (17). Complete assembly by aligning pins on Cab Base with openings on underside of Housing and glue together. Align pins on underside of Air Intake Cover (18) with openings in Engine Housing and glue together.

Boom Assembly

7) Glue Upper Hydraulic Lines (20) to top of Boom (19) and Cover (21) to underside as shown.

8) Insert - do not glue - pins on Pivots* (2x 23) to open ring at top of each Boom Ram* (2x 22), and to openings on Boom as shown.

9) Glue Lights (2x 24) to mounting points on left and right of Boom as shown.

10) Insert - do not glue - pins on end of Hydraulic Stick Cylinder* (25) to mounting points on top of Boom. Insert - do not glue - pins on Stick* (26) to mounting points at front of Boom. Insert - do not glue - end of Stick Ram* (27) into Cylinder; insert pins on other end to top of Stick. Glue Stick Cover (28) to openings at front of Stick.

11) Insert - do not glue - pins on top of Hydraulic Bucket Cylinder* (29) to mounting points on front of Stick.

12) Insert - do not glue - pins on bottom of Linkage* (31) between openings at lower front of Bucket* (30).

13) Insert - do not glue - Hydraulic Bucket Ram* (32) into lower end of Cylinder, and align open ring at top between top openings on Linkage. Insert - do not glue - front arm of Connector (33) through Linkage and Cylinder; insert - do not glue - rear arm through opening on Stick as shown. Place Connector Cover (34) over both arms and secure with a bit of glue on the ends.

14) Insert - do not glue - pins on top of Bucket Cylinder* to top front and pins on bottom of Stick* to openings on Bucket* as shown.

15) Insert - do not glue - bottom rings of Arm Cylinders (2x 35) to openings on Boom Support; insert - do not glue - Cylinder Retainer* (36) through openings as shown to secure both Cylinders.

16) Insert - do not glue - ends of Boom Rams* (2x 22) to openings at top of Arm Cylinders. Align - do not glue - openings on end of Boom with upper mounting points on Boom Support; insert - do not glue - Boom Retainer* (37) through openings in Boom and Support as shown.

17) Glue Handrail (38) to outside edge of Cab Base. Glue Hydraulic Lines (39) at front and rear of Boom Support as shown. Glue Exhaust Stack (40) to rear of Engine Housing.

Cab Assembly

18) Align opening on underside of Cab Floor (41) with pin on Cab Base and glue together. Glue Seat (42) to Floor and glue Pedal (43) to open area in front of seat as shown. Glue Access Cover (44) to opening at rear of Base. The Cab Glass (45) is a press-fit in the Cab (46), but may be carefully glued in place if desired. Glue Cab Rear Wall (47) to back of Cab. Complete assembly by gluing Mirrors (2x 48) to Handrail and Cab as shown.

