



N Structure Kit  
**CONCRETE GRAIN ELEVATOR**  
933-3225

Thanks for purchasing this Cornerstone Series. kit! Please read all instructions before starting. All parts are molded in styrene plastic. so use glues and paints which are compatible.

Throughout the "breadbasket" of America and Canada, the local grain elevator with its tall tower and storage silos is a common sight. Not limited to small towns, they can also be found in most major cities, especially those with river or ocean ports. The basic function of the elevator is the purchase of all types of edible grains, either for use by a parent company, or for resale on the open market. The grain will often be stored for a time, waiting for better prices or the arrival of empty rail cars, and may have to be dried to prevent spoilage.

Grain is received by truck (or rail at larger terminals) and moved on an underground conveyor system to the head house (tower). Using compressed air, the grain is moved through a system of pipes and distributed into the various storage silos. This creates a considerable volume of highly inflammable grain dust, which is constantly filtered from the air using large dust collectors. Moving the grain from the elevator to market has long been a job for railroads, and some lines were built especially to serve grain-growing regions. As a result, the grain elevator is one of the most common trackside industries. Because of the rapid turnover of cars on a year-round basis, they make ideal industries for model railroads as well.

A wide range of passenger cars, figures, vehicles and accessories are available to set the scene. See your dealer, or check out the latest Walthers N&Z Scale Model Railroad Reference book or visit our Web-site at [www.waltherscornerstone.com](http://www.waltherscornerstone.com) for more ideas.

#### GENERAL ASSEMBLY INSTRUCTIONS

1. All parts should be test-fit before actual assembly. Any flash, molding gates or other extra material that interferes with a tight fit should be removed with a hobby knife or file.
2. If you intend to paint the model, painting should be done before assembly. Windows and doors are most easily painted while still attached to the sprue. Decals do not adhere well to bare plastic. If not painted, surfaces to which decals are to be applied should be sprayed with a clear semi-gloss finish.  
After the decals are dry the entire structure can be sprayed with a clear flat finish to protect the decals and eliminates plastic "shine".
3. Wherever practical, gluing should be done by holding the parts in position and applying liquid plastic cement to the joint with a small brush. Wall joints should be glued from the inside. If parts have been painted, best results are obtained if the paint is scraped from the joining surfaces.

1. Glue doors (20) and windows (37) to walls (40, 45) as shown. Glue window glass (38) to back of doors as shown. Push I-Beam (22) through opening in on wall (45) and glue in place. Glue dust collector halves (25, 26) and top (28) together. Glue bracing (23, 24) together. Glue dust collector assembly to brace assembly. Glue to roof using locators. Glue pipe (27) in position as shown. (repeat for 2nd collector)

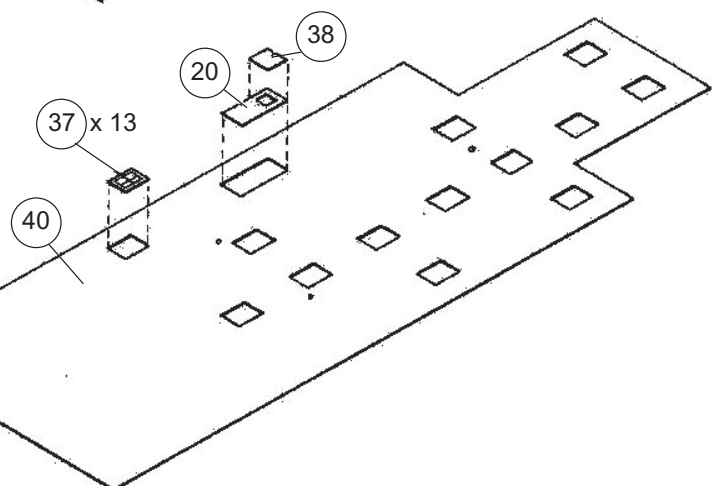
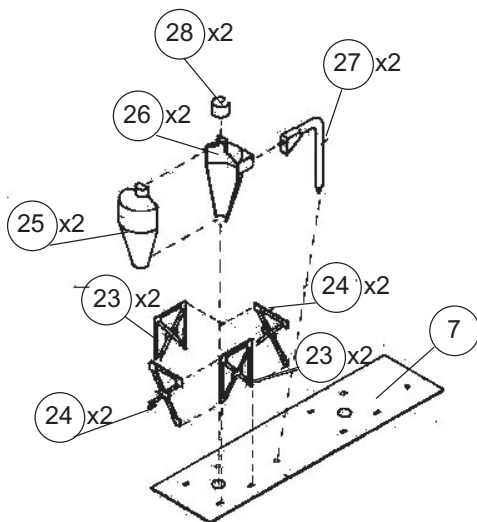
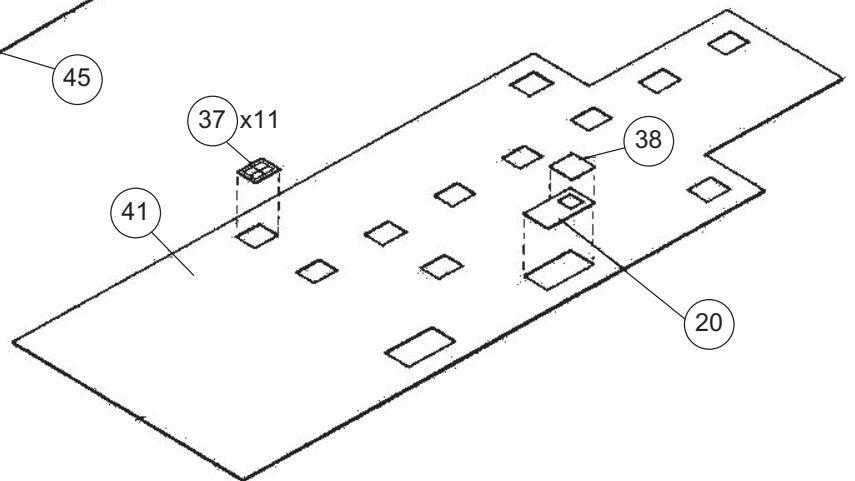
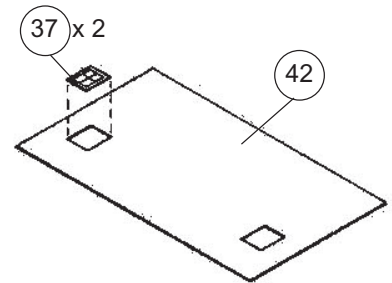
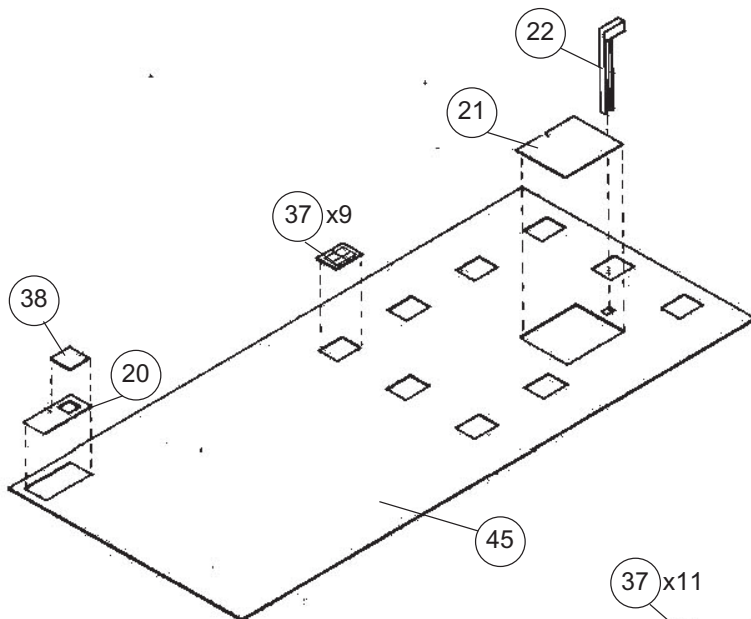
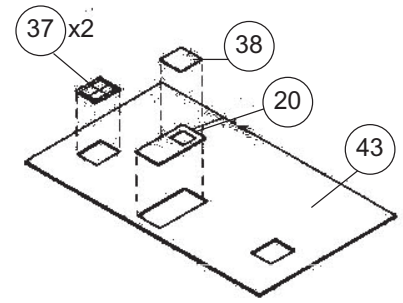
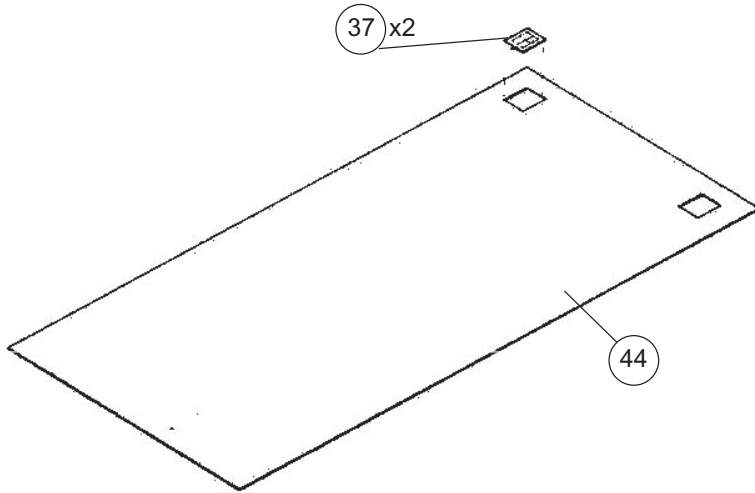

2. Glue the walls (40, 41, 44, 45) together and to base (47). Glue track shed (11, 12, 13, 14) together and to wall (40) above ridge. Glue pipe brace (29) into holes in wall (40). Glue pipe (30) to wall (40) and to hole in roof of track shed.

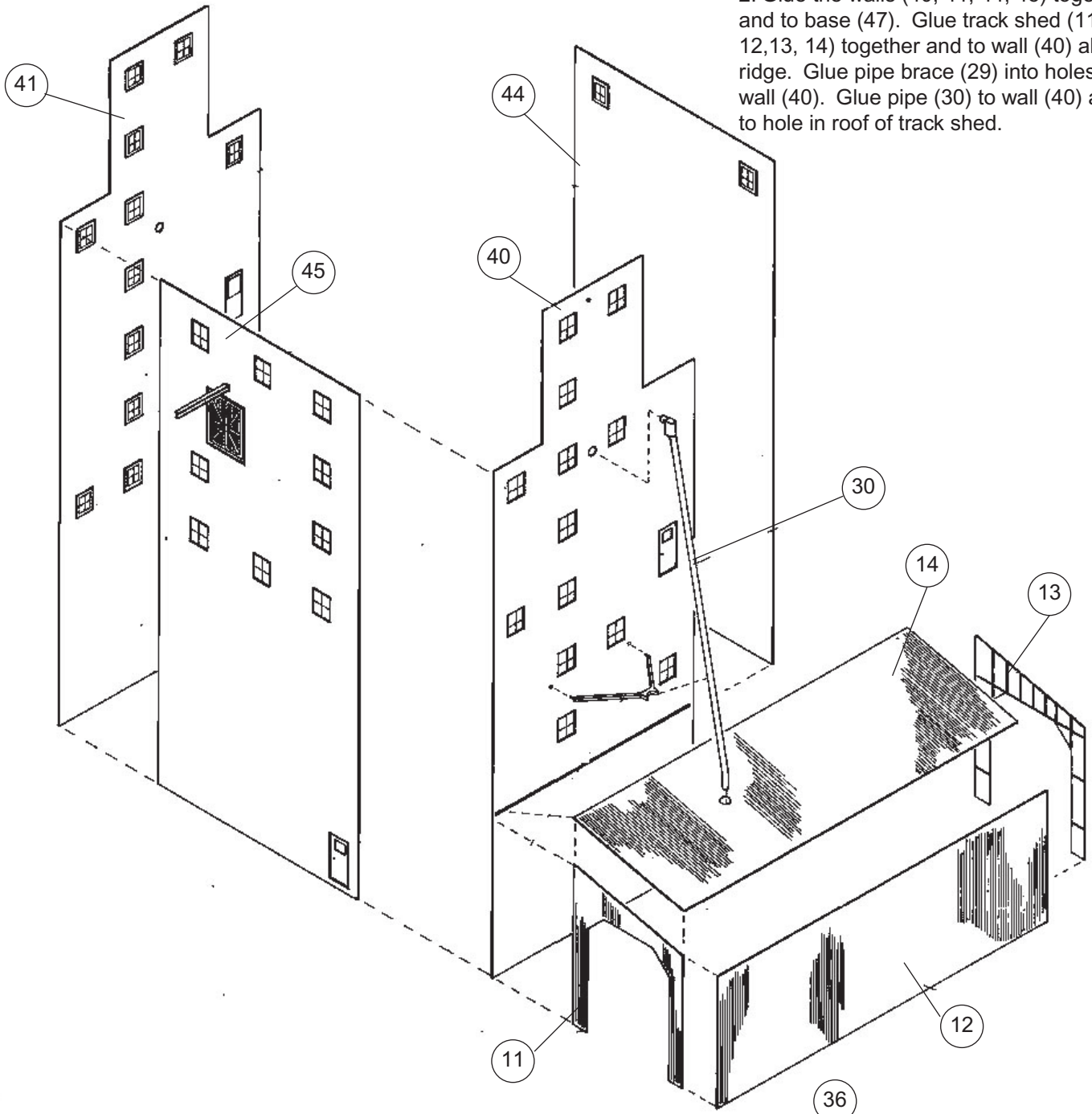

3. Glue windows (39) in place. Glue headhouse walls (32, 33, 34, 35) together. Glue roof halves in place.

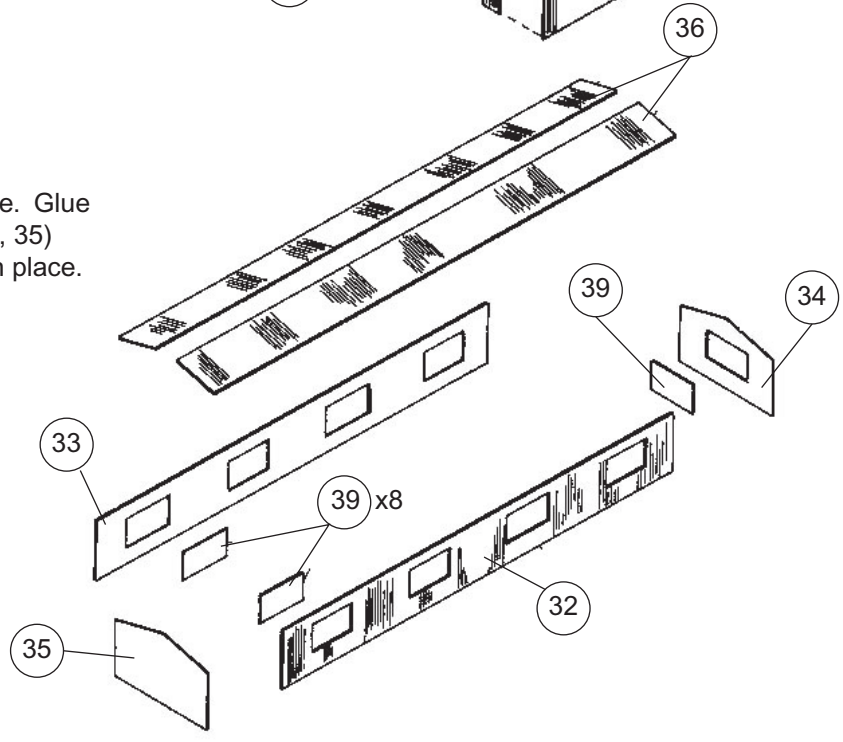

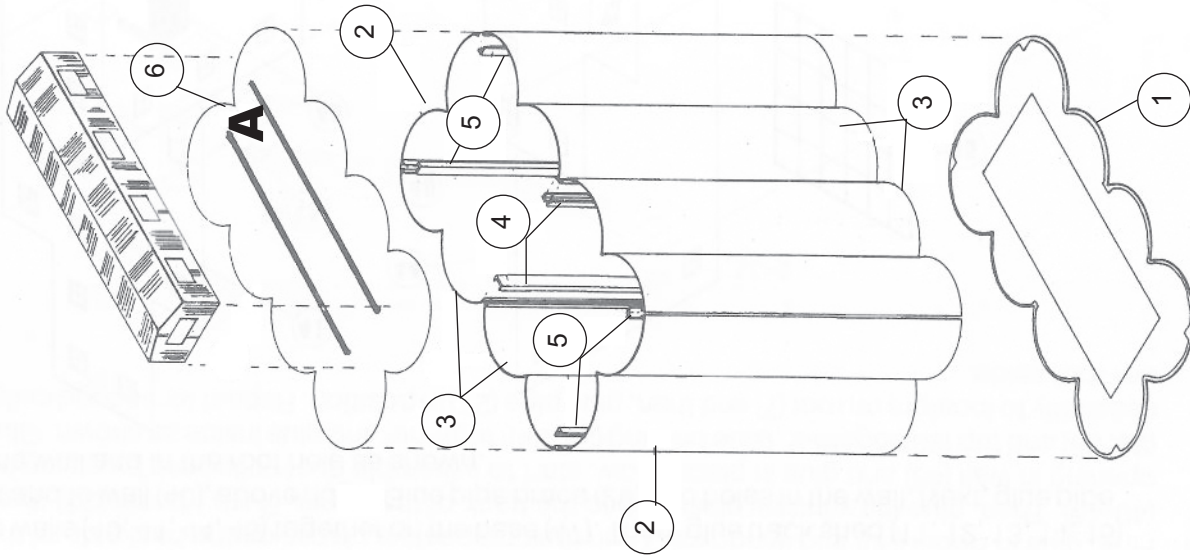

4. Glue silo sides (3) and ends (2) together along with sides (4) and end (5) Braces. Next glue silos to base (1).  
Glue roof (6) on as shown.

5. Glue truck shed (16, 17, 18, 19) together. Glue train shed wall (15) to main structure. Glue truck shed to main structure (roof goes above ridge). Glue pipe (31) to wall and into hole in roof of truck shed. Glue roofs (7, 8, 9) in place along with vents (46). Glue head house to top of silos. Place silos next to elevators (B to B)

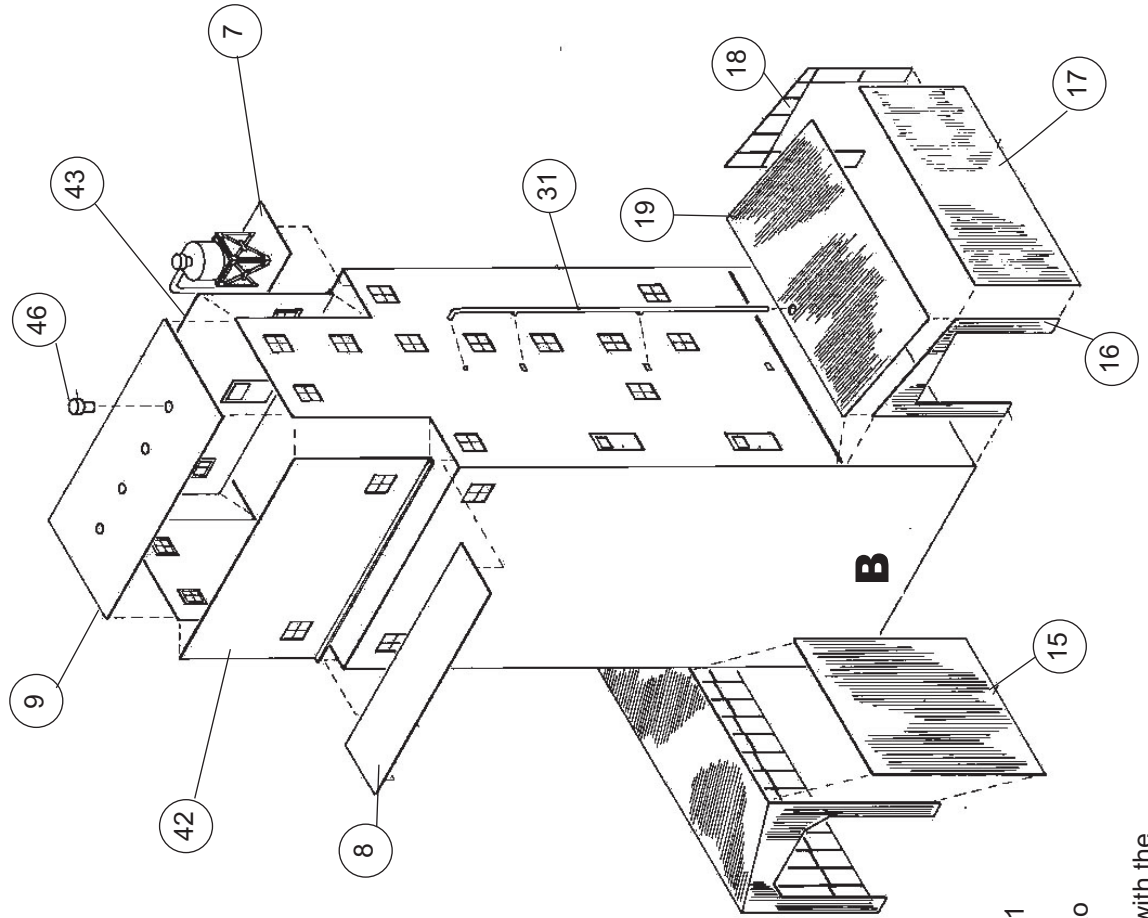

#### DECALING

1. After cutting out the decal, dip in water for 10 seconds, remove and let stand for 1 minute. Slide decal onto surface, position and then blot off any excess water.
2. Lightly brush Micro Sol® on top. This will soften the decal allowing it to conform to irregular surfaces. DO NOT TOUCH DECAL while wet!
3. When the decal is thoroughly dry, check for any trapped air bubbles. Prick them with the point of a small pin or hobby knife blade and apply more Micro Sol®.